

## Plastic Welding Equipment Bending Bars

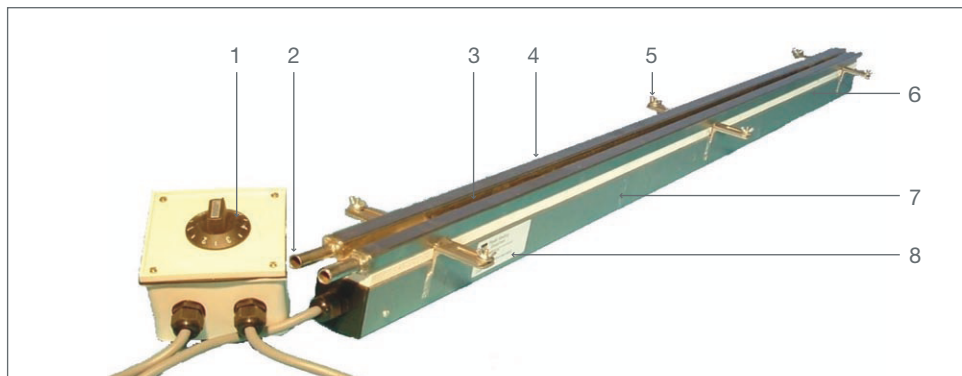

- 1 Temperature adjustment
- 2 Connection for water circulation
- 3 Electric element
- 4 Stainless steel water jacket
- 5 Wing nut for radius adjustment
- 6 Ceramic fibre insulation
- 7 Body
- 8 FHS decal

### OVERVIEW

A 240 volt electric element (3), is set into a base of ceramic fibre insulations (6). On either side of the element there are stainless steel water jackets (4), which keep the machine cool. Water must be flowing through the jackets at all times and chlorine must not be used in the water. The water jackets allow the heat to rise in a defined area. This will give a straight line bend. All machines should be fitted with correct fitting hose and hose clamps.

### Plastic sheet bender

- 4 lengths available
- Adjustable heat
- Variable distance between cooling jackets allowing for different radius and sheet thickness
- Stainless steel water jackets

Bending bar 1300mm heated area	4101300
Bending bar 2175mm heated area	4102175
Bending bar 2540mm heated area	4102540
Bending bar 3020mm heated area	4103020